

FLORIDA POLYTECHNIC UNIVERSITY
DEPARTMENT OF PROCUREMENT
INVITATION TO BID
DISHWASHING MACHINE FOR CAMPUS DINING
LEASE OPTION
ITB 24-074

THIS IS NOT AN ORDER – PLEASE READ DOCUMENT CAREFULLY

COMMODITY/SERVICES: LEASED EQUIPMENT - DISHWASHING MACHINE FOR CAMPUS DINING	PROCUREMENT CONTACT: ANDREA CASHELL EMAIL: PROCUREMENT@FLORIDAPOLY.EDU	DATE: 3/22/2024
BID OPENING DATE/TIME: 03/29/2024 2:00 PM (ET)	QUESTION DEADLINE: 3/26/2024; 2:00 PM(ET)	PRE-BID CONFERENCE: N/A
RESPONDENT NAME: ADDRESS: EMAIL: PHONE:		

1. Bids will be publicly opened and reviewed by the Procurement Department at the time and date stated above. Details will be available on Procurement’s website. <https://floridapoly.edu/procurement/solicitations/index.php>
2. Please submit your best offer. The University is not liable for any costs incurred by Respondent in responding to this Competitive Solicitation.
3. Bids must be firm. Those containing escalator clauses cannot be accepted. To receive consideration, bids must be made on this form and signed in full.
4. Has Respondent declared bankruptcy, otherwise been declared insolvent, has had a delinquency judgement issued against it in any court of competent jurisdiction, has been placed in receivership, or is involved in any litigation?
5. Has Respondent had any agreements/contracts within the last three years where liquidated damages, penalties, liens, judgments, defaults, cancellations of contract or termination of contract were filed against the Respondent?
6. Does Respondent seek to assert trade secret protection for any document the Respondent submits in response to this Competitive Solicitation, under Sections 119.0715, 688.002(4), 812.081(1)(c), 815.04(3), and/or 815.045, Florida Statutes?

AUTHENTICATION OF BID AND STATEMENT OF NON-COLLUSION AND NON-CONFLICT OF INTEREST

1. Respondent’s collusion with other Respondents, other Respondents’ employees, or any employee of the University is prohibited and may result in rescission or cancellation of solicitation (or contract) without liability to the University.
2. Respondent is legally entitled to enter into a contract with Florida Polytechnic University.
3. The award of this Competitive Solicitation is subject to the provisions of Chapter 112, Florida Statutes, and any other laws, regulations and/or policies concerning conflicts of interest in dealing with entities of the State of Florida (collectively, “Conflicts of Interest Rules”).
 - a) In accordance with Section 112.3185, Florida Statutes, by submitting a Response, the Respondent certifies that no individual employed by the Respondent or subcontracted by the Respondent has an immediate relationship to any University employee or public officer who was or is directly or indirectly involved in any way in the drafting, evaluating, or awarding of this Competitive Solicitation. (See Attachment A, Section 3.)
 - b) Solely by way of example, Respondent must disclose in its Response the name of any officer, director, or agent of the Respondent who is also an employee or public officer of the University. Further, Respondent must disclose in its Response the name of any University employee or public officer (or his or her spouse or child) who owns, directly or indirectly, an interest of five percent (5%) or more of the Respondent’s company or any of its affiliates or branches. (See Attachment A, Section 4.)
 - c) Failure to disclose the required information or violation of the Conflicts of Interest Rules is grounds for the University’s rejection of Respondent’s Response, cancellation of an intent to award to Respondent, and/or cancellation of any contract with the Respondent.

CERTIFICATION OF NON-SEGREGATED FACILITIES

The Offeror, by submitting a proposal, certifies that he/she is in compliance with the Code of Federal Regulations, 41 CFR 60-1.8 that prohibits the maintaining of segregated facilities. We understand and agree that a breach of this certification is a violation of the Equal Opportunity clause required by Executive order 11246 of 24 September 1965.

By filing a Response, Respondent certifies that Respondent is not on the convicted vendor list maintained by the Florida Department of Management Services, and Respondent also certifies that any subcontractor listed in Respondent’s solicitation response is not on the convicted vendor list. Any documents Respondent submits to the University in response to this Competitive Solicitation become the property of the University and become public records.

SIGNATURE REQUIRED – I hereby swear under the penalty for false swearing:

1. I am the Respondent, a partner or an Officer or employee of the Respondent with authority to sign on its behalf (if the Respondent is a firm).
2. The information provided in this document is accurate and complete.
3. Respondent is legally entitled to enter into contracts with the Florida Polytechnic University Board of Trustees.
4. Respondent is aware of and has complied with the requirements of the Conflicts of Interests Rules and filed with the State of Florida.
5. Respondent’s Response remains valid for six (6) months after the Response Due Date.

Government Classification (check all that apply): W/MBE <input type="checkbox"/> Small Business <input type="checkbox"/> Veteran Business <input type="checkbox"/> Local Business <input type="checkbox"/> Other (Please identify): _____ - _____
Signature of Respondent’s Authorized Representative: Date:

1. DEFINITIONS

Addenda/Addendum – Written or graphic instruments issued by the Department of Procurement prior to the date for opening of responses, that modify or interpret this Competitive Solicitation by additions, deletions, corrections, or clarifications.

Procurement Website - <https://floridapoly.edu/procurement/solicitations/index.php>

Respondent – A firm or individual submitting a Response to this Competitive Solicitation (Vendor, Offeror, Respondent, Contractor, Supplier etc.). Response - An executed offer submitted by a Respondent in response to this Competitive Solicitation.

Successful Respondent - A recommended recipient of an award of a contract under this Competitive Solicitation

Contract – Will be provided as a Notice of Award. All University Terms and Conditions apply.

2. PREPARATION OF RESPONSES

(a) Each response shall furnish the information required by the solicitation. The Respondent shall sign the solicitation.

(b) Response must be submitted on the Cost Proposal/Schedule sheet. See attachment A..

(c) Responses for goods/services other than those specified will not be considered unless authorized by the solicitation.

(d) Time, if stated as a number of days, will include Saturdays, Sundays and holidays.

(e) Response must include at least three references from companies that the respondent has provided services to during the last five years. Provide company name, address, and contact name and phone number.

3. PRE-BID CONFERENCE (NON-MANDATORY) -

N/A

4. QUESTIONS

All questions regarding this ITB shall be made electronically via e-mail in writing and directed to PROCUREMENT@FLORIDAPOLY.EDU no later than March 26, 2024, 2:00 PM (ET). The subject of the e-mail shall be "QUESTION -ITB 24-074". Failure to provide the correct ITB number in the email may deem the question unanswerable and may not be considered as part of any addenda. Any questions submitted after the dates and times may not be considered or answered. Questions properly submitted in writing prior to the due date will be addressed in an Addendum and posted on the [Procurement Website](#).

5. EXPLANATION TO OFFERORS

Any explanation desired regarding the meaning or interpretation of the solicitation, drawings, specifications, etc., must be requested in writing and with sufficient time allowed. Oral explanations or instructions given before the award of the contract will not be binding. Any information provided will be posted on the [Procurement Website](#).

6. ACKNOWLEDGMENT OF ADDENDUM

Addendum must be acknowledged by signing and returning the amendment or by letter to procurement@floridapoly.edu.

7. SUBMISSION OF RESPONSES

(a) Response must be submitted to procurement@floridapoly.edu on or before the bid opening date/time.

(b) Late responses and modifications* received by the Procurement Department after the time and date specified may not be considered.

*Responses may be modified or withdrawn by written notice prior to the time and date specified for receipt of bids.

(c) Responses may be withdrawn in person by a Respondent or authorized representative, and must sign a receipt for the offer, prior to the time and date specified for receipt of bids.

8. AWARD OF CONTRACT

(a) The contract will be in the form of a Notice to Award a Contract and be awarded to the Respondent(s) whose offer conforming to the solicitation will be most advantageous to the University and other factors considered.

(b) The University reserves the right to reject any or all offers and to waive informalities and minor irregularities of responses received. A written communication by the Procurement Representative to the successful Respondent will be provided to the successful Respondent.

(c) Contract term will be from date of award until lease and/or warranty is expired.

9. COMPLIANCE

It is agreed and understood that any contracts and/or orders placed as a result of this ITB shall be governed under Florida Board of Governor Regulation and Florida state laws.

10. CONTRACT CHANGES:

During the period of contract, no change will be permitted unless the Contractor receives written approval from the Director of Procurement. If changes are necessary, Respondent must promptly report such matter to the Director of Procurement for consideration.

GENERAL OVERVIEW

1. INTENT AND SCOPE

Florida Polytechnic University Board of Trustees is soliciting bids from interested parties to lease a commercial grade dish machine and booster heater to install in the campus dining facility.

Florida Poly reserves the right to reject any and all bids, or any part thereof, negotiate changes in bids, accept any bids or any part thereof, waive minor informalities or defects in any bids, and not to award the proposed contract if it is in the best interest of Florida Poly.

Florida Poly shall not be held responsible for Respondent's lack of understanding of what is required by this bid. Should a Respondent not understand any aspect of this bid, or require further explanation, or clarification regarding the intent or requirements of this bid, it shall be the responsibility of the Respondent to submit questions to the appropriate Procurement Official.

This solicitation is not to be construed as a commitment of any kind nor does it commit the University to pay for any costs incurred in the submission of an offer or for any other incurred cost prior to the execution of a formal contract.

2. REQUIREMENTS

2.01 Equipment Requirements:

Florida Polytechnic University Board of Trustees hereby invites respondents to submit bids for lease on the equipment listed below and/or equivalents:

- A. Dish machine: CMA EST-66 208v 3ph R/L w/adapters.
 - A.01 See Specs on Attachment B
- B. Booster Heater: Hubbell J636R 208v 3ph Stand Alone Booster
 - B.01 See Specs on Attachment C

Respondent will provide leasing options on attachment A for the above equipment.

Bids on equivalent items, substantially the same, are invited. However, to receive consideration, sufficient specifications clearly identifying the item including pricing must accompany the bid and be included on Attachment A. The University will be the sole judge of equality and suitability.

Failure to provide specifications concerning alternative items proposed may result in the rejection of the bid.

2.02 Service Requirements:

- A. Successful Respondent will provide, at own cost, all maintenance and repairs on equipment.
- B. Successful Respondent will provide, at own cost, all parts, materials, and chemicals required to maintain the equipment.
- C. Cost proposal must include all charges including but not limited to, cost of equipment, lease rate, security deposit, installation charge, equipment delivery charge, monthly service charge for preventative maintenance and service calls.

2.03 Performance Of Work:

A. While on University Property, Successful Respondent and all associated contractors must abide by the following:

- All Vendor staff must be in uniform and equipped with the proper Personal Protective Equipment.
- No shirtless or torn attire will be permitted.
- Vehicles must be clearly marked and parked where the University permits. No personal work vehicles will be permitted.
- No smoking, loitering, fishing, or eating in or around buildings is permitted.

- Discourteous acts towards any person will not be permitted
- Must check in with the point of contact for the University.
- Must contact the University within 48 hours of the scheduled work if the planned activity has been rescheduled.
- Must take precautions at all times utilizing safety equipment, and remain in compliance with OSHA Standards at all times.
- Must provide an emergency response point of contact in the event of emergencies that may impact life safety, or damage University property.
- Vendor must be aware of any potential hazards before work is initiated.
- Vendor shall obtain, at its own expense, all necessary permits and licenses required by federal, state, County or local orders, codes, ordinances, regulations, administrative codes, laws, and Florid Poly
- The vendor shall provide comprehensive insurance to date with the University named as a certificate holder made out to the Florida Polytechnic University Board of Trustees. The University shall also be listed as additional insured.
- Any changes, improvements, or alternates must be submitted to the University contact and written approval by the appropriate University Representative.
- Contractor agrees that work will not be brokered or subcontracted without prior written approval from the University.

3. QUALIFICATIONS OF RESPONDENT

Any vendor who responds to this solicitation must meet the following minimum qualifications in order to be considered responsive:

- Be in the business of leasing equipment as part of its normal business operation.
- Has the legal authority to represent and lease the equipment offered.
- Have the authority and capacity to provide full support for all product warranties, including technical "trouble shooting" support.
- Include with proposal a list of at least three (3) references with whom a financial transaction, similar to this project, has been conducted within the last 24-month period. This list should include the company name, address, telephone number and contact name. See Attachment D.
- All sample contract documents as well as proposed terms and conditions must be submitted with bid.
- Be able to provide audited financial statements demonstrating the financial ability to meet the requirements of any order that may result from this solicitation.

4. AWARD CRITERIA

An award will be made to the lowest, responsive, responsible Respondent that meets the requirements as set forth in the specifications and compliance thereof. Florida Poly reserves the right to determine that all offered equipment will serve the application intended.

Florida Poly may award a contract resulting from this solicitation to the responsive offeror whose offer conforming to this solicitation will be the most advantageous to the Florida Poly.

Any resulting contract from this solicitation shall incorporate the Standard Instructions, and General Terms and Conditions incorporated in this solicitation.

5. DELIVERY DATE

Your bid should indicate the earliest firm delivery date. Florida Poly shall fully expect the successful Respondent to completely satisfy contract performance requirements in accordance with firm delivery date offered in the Cost Schedule.

Florida Poly requires Successful Respondent to have the equipment installed and ready for use no later than August 1, 2024

6. METHOD OF BIDDING

Respondent shall submit responses as indicated within this ITB. No other method of bidding will be considered. Respondent must use the (name of bid form) which is included and made a part of this Invitation and include all data and other information requested in said Form of Proposal must be supplied.

7. RECIPROCAL AND OTHER PREFERNCES

The Procurement Department will also review the Responses to determine if any preferences should be applied. The University will provide preferences to eligible Respondents in accordance with Board of Governors regulation 18.001, and Sections 287.084, 287.087, and 287.092, Florida Statutes, as applicable. There is a preference for Florida Based Vendors for purchases of personal property; a preference is provided to Respondents with a principal place of business in Florida.

8. INSURANCE

The Respondent shall provide and include in bid price the cost of the following minimum insurance coverage:

- (a) Workers' Compensation \$1,000,000
- (b) General Liability \$1,000,000
- (c) Excess Liability \$1,000,000
- (d) Business Automobile Liability \$1,000,000 (each occurrence, any auto owned, non-owned, hired, or borrowed)
- (e) Public Liability \$1,000,000 Combined Single Limit
- (f) Property Damage \$1,000,000 Combined Single Limit

The minimum limit for Employers Liability coverage is:

- (a) \$100,000 Each Accident
- (b) \$500,000 Policy Limit Disease
- (c) \$100,000 Each Employee Disease

Insurance certificate needs to be on an "ACORD" Certificate of Insurance. The Florida Polytechnic University Board of Trustees must be shown as the Certificate Holder on the Certificate of Insurance and the additional insured.

The Successful Respondent agrees to furnish Certificates of Insurance for the above-described coverages and limits to Florida Polytechnic University Procurement.

ATTACHMENT A
 COST PROPOSAL/SCHEDULE – LEASE OPTIONS
 (Please Complete a Bid Sheet For Each Option That You Are Bidding)
 INVITATION NO.: ITB 24-074 DISHWASHING MACHINE FOR CAMPUS DINING SERVICE

Monthly Lease Payments

Item	Specification/Description	Monthly Amount	# of Months (Not to exceed 60 months)	Total	Rate Factor
1					
2					
3					
4					

Alternate Proposal

Item	Specification/Description	Monthly Amount	# of Months	Total	Rate Factor
1					
2					
3					
4					

Delivery Date (no later than): _____

Installed and Ready for Use (no later than): _____

--	--	--	--	--	--

BID NOTES / ADDITIONAL SPECIFICATIONS: Bidders must offer firm rate.

Original lease documents must be included with bidder's response or must be delivered to the purchasing department no later than three (3) business days after bid opening. Failure to supply the original lease documents may result in rejection of your bid with award being made to the next lowest bidder complying with this requirement.

--	--	--	--	--	--



HIGH TEMPERATURE LOW TEMPERATURE CONVEYOR DISHMACHINE

EST-66

High Temperature-Low Temperature
66" Conveyor Dishmachine



Available as Left or Right.
(Must Specify)

FEATURES

- Automatic water control system.
- 249 racks / 996 covers per hour.
- Economical to operate. Uses only .46 gallons of water per rack of dishes.
- Single control switch activation.
- Power rinse heater system.
- Unique 4-stage washing process provides 2 wash stations, power heated rinse and final rinse all in a 66" machine.
- Automatic soil purging system filters wash water and traps plate debris into an external tray. Tray can be easily removed for cleaning.
- All stainless steel construction offers durable performance and years of trouble-free operation.
- Chemical resistant industrial heaters are proven to be more durable than commercial grade heaters.
- Large 19" opening accommodates larger items and utensils.
- Auto start/stop makes operation more energy efficient.
- Easy to remove and replace curtains for cleaning.
- Includes table limit switch and rack saver clutch system that protects the machine, dishracks and table from damage.
- 316 grade stainless steel chemical injection chamber.

CMA MODEL: EST-66

AVAILABLE OPTIONS

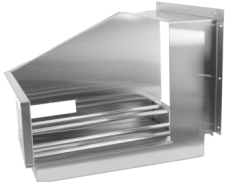

Corner Feed Table
Left or Right: must specify
Factory Installed Only



Vent Hoods 4" x 16"
with Damper Control (2 per set)



Sheet Pan Rack



E-Temp
CMA Booster Heater (40° and 70° rise)
Only available in 3 phase with 70° rise
Standard voltage 208-230V three phase
Factory Installed Only

- Stainless Steel dishtables
- Drain Water Tempering Kit
- Scrap Trap Single Drain Connection Kit
- 208V-240V / 480V
- Exhaust Fan Control
- Hatco Booster Heater (specify voltage & phase)
- 6" Taller Model Available (EXT)





EST-66

High Temperature
Low Temperature
66" Conveyor Dishwasher

WARNINGS:

- Plumbing connections must be made by a qualified service company who will comply with all available Federal, State, and Local Health, Plumbing and Safety codes.
- CMA recommends utilizing a water softening system to maintain water hardness measurements of 3.5 gpg (grains per gallon) or less. This will assure maximum results and optimum operation of the dishmachine.

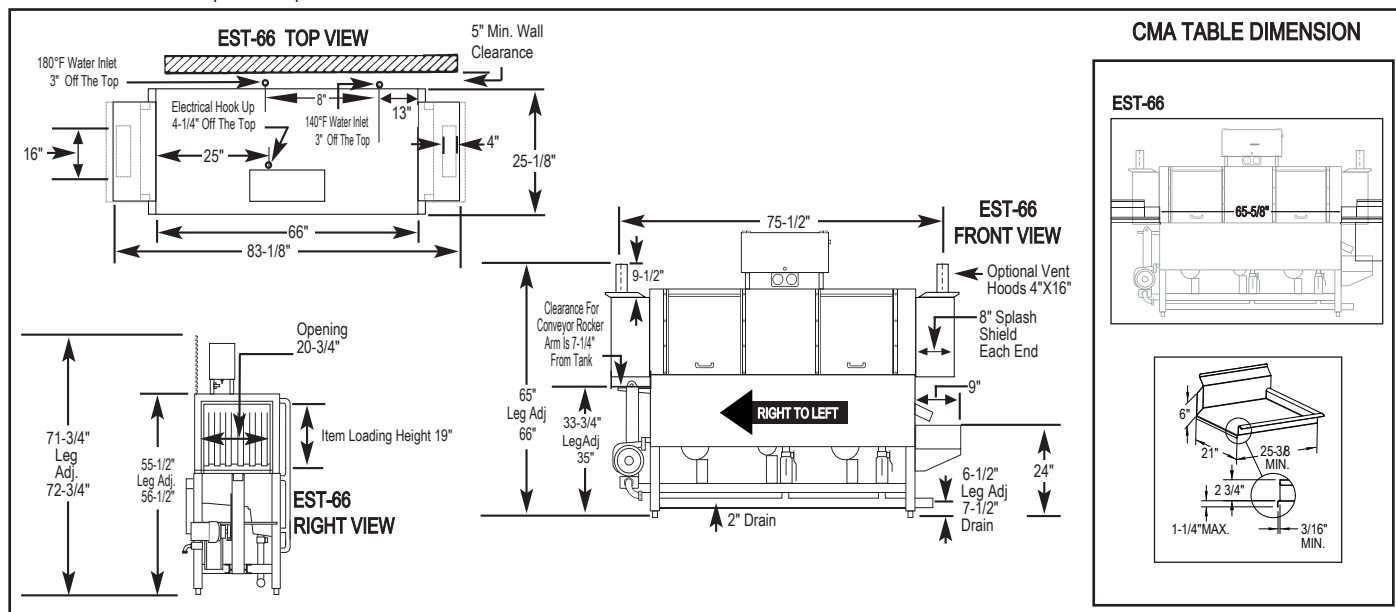

Specifications:

MODEL EST-66 H/L	USA	METRIC	USA	METRIC
OPERATING CAPACITY RACKS PER HOUR (NSF RATED)243	249	249	DIMENSIONS	
CONVEYOR SPEED	6.75 FT./MIN.	(206 CM/MIN.)	DEPTH	25-1/8" (64cm)
WASH PUMP MOTORS HP	1	1	WIDTH	66" (167.64cm)
RINSE PUMP MOTOR HP	1/3	1/3	HEIGHT	55-1/2"-56-1/2" (142-143cm)
CONVEYOR MOTOR HP	1/8	1/8	STANDARD TABLE HEIGHT	34" (86cm)
WATER INLET - FILL	1/2"	(1.27cm)	MAX LOADING HEIGHT FOR WARES	19" (48cm)
WATER INLET - FINAL RINSE	1/2"	(1.27cm)	STANDARD DISHRACK DIMENSIONS	1 20" x 20" (50.8 X50.8cm)
DRAIN SIZE	2"	(5.1cm)	ELECTRICAL RATING	VOLTS
FINAL RINSE PRESSURE	20 ±5psi	(1.41 kg/cm²)		PHASE
WASH TANK CAPACITY EST-66				AMPS
PRE-WASH	2.5 GAL	(9.5 L)		
WASH	11.75 GAL	(44.5 L)		
PRE-RINSE	4.25 GAL	(16 L)		
TOTAL	18.5 GAL	(70.0 L)		
WASH PUMP CAPACITY				
EACH	52 GPM	(197 LPM)		
OPERATING TEMPERATURE EST-66H			WASH TANK HEATER	13kW @ 208V (3 PHASE)
WASH	150°F-160°F	(66°C/71°C)	RINSE TANK HEATER	3kW @ 220V
PUMPED RINSE	160°F	(71°C)		
FINAL RINSE	180°F-195°F	(82°C/90°C)		
OPERATING TEMPERATURE EST-66L			SPECIFY DIRECTION OF RACK TRAVEL (RIGHT TO LEFT, LEFT TO RIGHT) WHEN ORDERING	
WASH RECOMMENDED	140°F-150°F	(60°C/68°C)	EST-66H EXHAUST VENTILATION REQUIREMENTS AT 100% CAPACITY CFM	
PUMPED RINSE RECOMMENDED	140°F-150°F	(60°C/68°C)	ENTRANCE END 200 MAX	DISCHARGE END 400 MAX
FINAL RINSE RECOMMENDED	140°F-150°F	(60°C/68°C)		TOTAL CFM 600 MAX
WATER CONSUMPTION			SHIPPING WEIGHT	
PER RACK (FINAL RINSE)	.46 GAL	(1.7 L)	APPROXIMATE	750# (340kg)
PER HOUR (FINAL RINSE)	114.54 GPH	(433.6 LPH)		

Summary Specifications: Model EST-66 Conveyor

The Models EST-66H high temperature and EST-66L Chemical Sanitizing conveyor dishwashers meets ETL sanitation, UL, and CUL construction standards. The EST-66 performs three separate washing functions including a built-in power rinse, all in a 66" space. The EST-66 washes up to 249 racks per hour and uses a mini-mum .46 gallons of water per rack while achieving sparkling, clean, dry dishes. Constructed entirely of stainless steel.

Call For Available Models (800-854-6417) or See web-Site: www.cmadishmachines.com Advisory: CMA does NOT endorse "Tankless On-Demand" water heaters for use on CMA Dishmachine products. CMA DOES endorse, and highly recommends, the standard "tank" style water heaters, sized properly to handle each particular facility with their water heating requirements.



CMA Dishmachines 12700 Knott Street Garden Grove, CA 92841 • 800-854-6417 • 714-898-8781 • Fax: 714-895-2141 • www.cmadishmachines.com

CMA reserves the right to modify specifications or discontinue models without prior notification.

© 3-2020 CMA, Inc.

an Ali Group Company



The Spirit of Excellence

ITEM NO.	QTY.	PART NO.	MATERIAL	DESCRIPTION
1	1	J6-6 TANK	304L S/S	TANK ASSEMBLY
2	1	J6 INLET	BRASS	3/4" MNPT INLET
3	1	J6 OUTLET	BRASS	3/4" MNPT OUTLET
4	1		BRASS	3/4" FNPT FOR RELIEF VALVE
5	1	100XL .75 150LB	BRONZE	RELIEF VALVE SET AT 150PSI, 210°F
6	1	J6-6 JACKET	304 S/S	TOP COVER ASSEMBLY
7	1	J6-6 FRONT COVER	304 S/S	FRONT COVER ASSEMBLY
8	1	J6-6 BASE	304 S/S	BASE ASSEMBLY
9	1		FOAM	INSULATION
10	4	61649NOBN5T4	PLASTIC	ADJUSTABLE LEGS
11	6	C1315-5	BRASS PLUG & COPPER SHEATH	HEATING ELEMENT - 1-7/8" HEX 6000W @ 208V
12	1	T1000	VARIOUS	CONTROL MODULE
13	2	C25DNF350B	VARIOUS	MAGNETIC CONTACTOR 65A (RESISTIVE) - 240V
14	1	KA4C	COPPER	GROUND LUG
15	1	J6-6 CONTROL PLATE	GALVANNEAL	ELECTRICAL MOUNTING PANEL
16	1	TD1000	VARIOUS	DIGITAL DISPLAY MODULE
17	1	P65	VARIOUS	PROBE ASSEMBLY
18	1	OVERLAY J MODEL	LEXAN	OVERLAY FOR DISPLAY MODULE
19	1		VARIOUS	LEAK DETECTION SENSOR
20	1	TTD405	VARIOUS	T&P GAUGE 30-240°F/0-200PSI
21	1	N45BU	BRONZE	PRESS. REDUCING VALVE 25-75PSI
22	1	PDB175-1X4-3	VARIOUS	POWER DISTRIBUTION BLOCK 175A, 3-POLE, 1 PRIM., 4 SEC.

REVISIONS				
ZONE	REV.	DESCRIPTION	DATE	APPROVED
-	-			

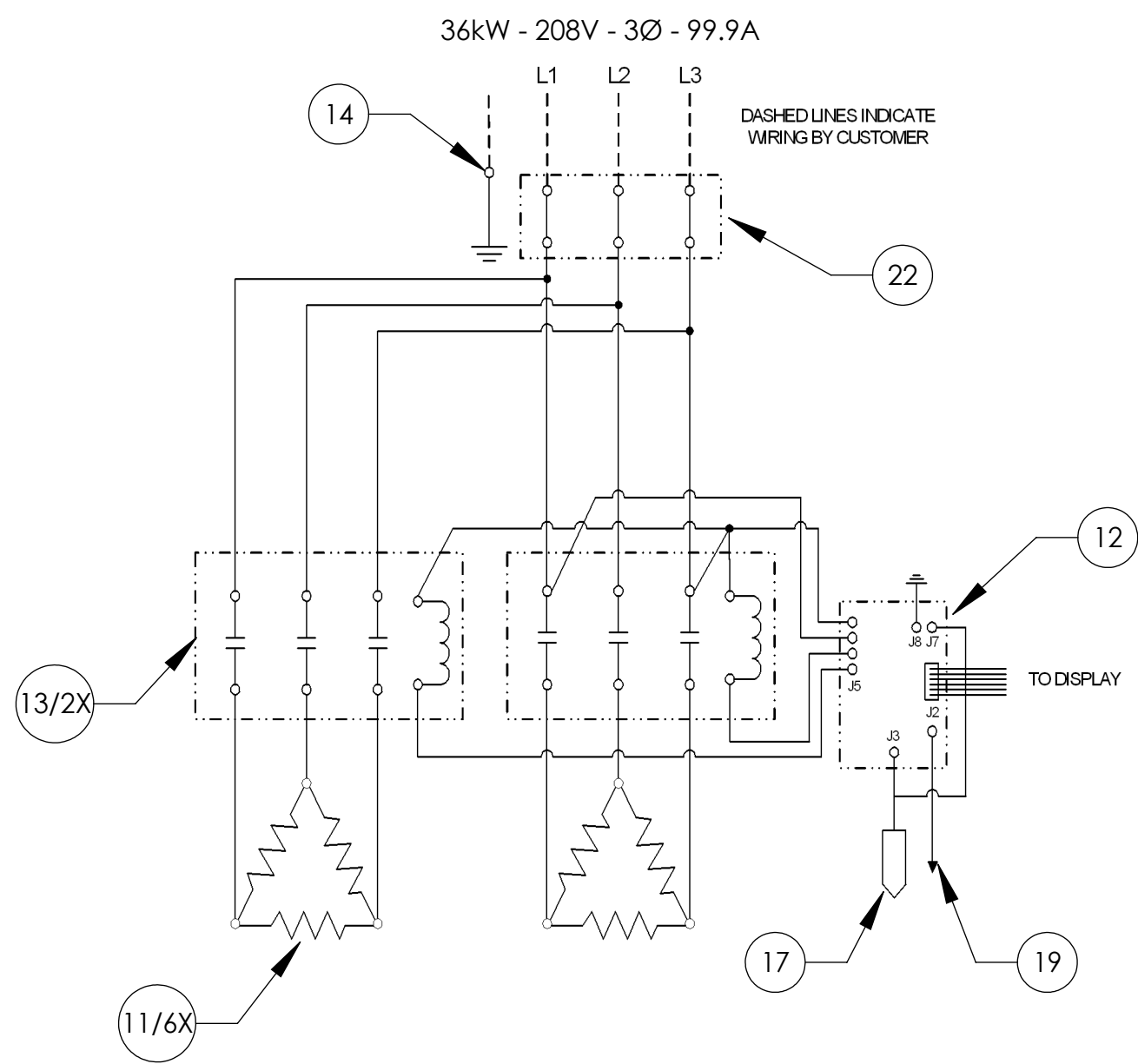

- NOTES:
- TANK IS DESIGNED, FABRICATED, AND STAMPED IAW ASME SECTION VIII CODE, LATEST ADDENDA.
 - TANK IS DESIGNED FOR 150PSI AND PRESSURE TESTED AT 225PSI.
 - PROBE ASSEMBLY (Pc. No. 17) PROVIDES TEMPERATURE CONTROL, HI-LIMIT, AND LOW WATER SENSING.
 - UNIT IS UL, CUL, AND UL EPH LISTED.
 - PIECE NOS. 5, 10, 20, AND 21 ARE SHIPPED LOOSE.
 - CONTROL CIRCUIT WIRE TO BE #18 TEFZEL 750 (200°C), POWER CIRCUIT WIRE TO BE #8 TEFZEL 750 (200°C). ELEMENT JUMPER WIRE TO BE #10 TEFZEL 750 (200°C).
 - PHASE TO PHASE RESISTANCE: 2.4 OHMS
 - APPROX. WEIGHT:
DRY: 98 LBS.
WET: 146 LBS.

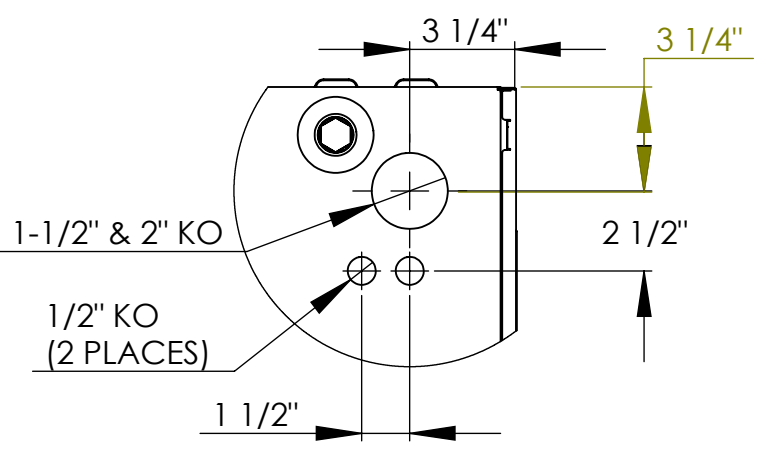
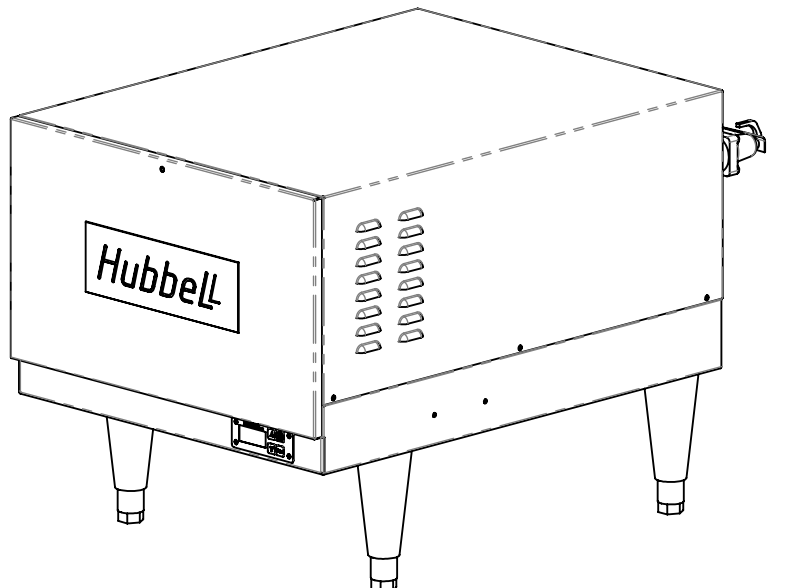
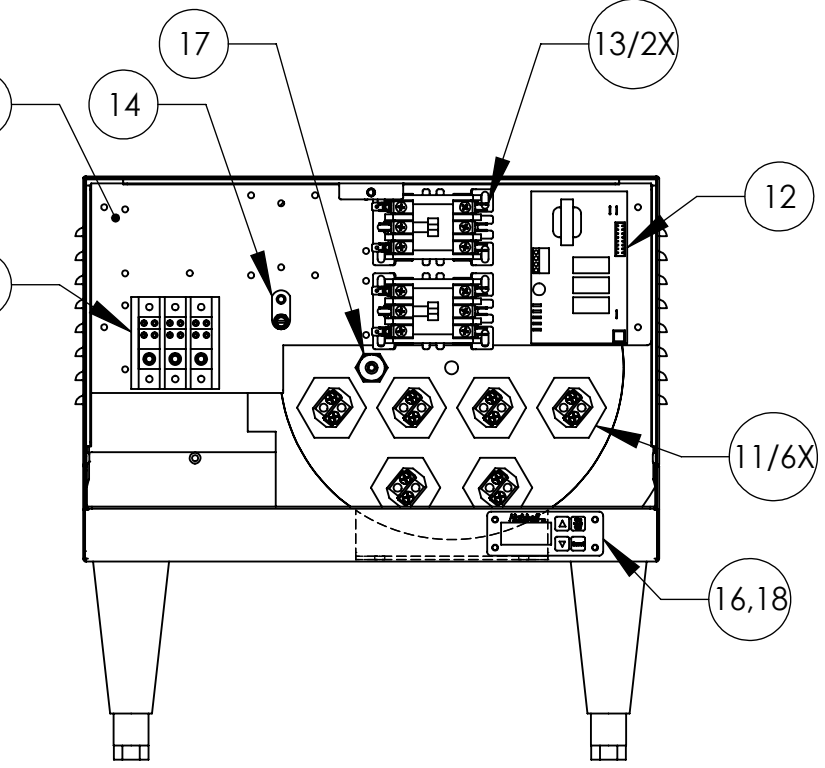
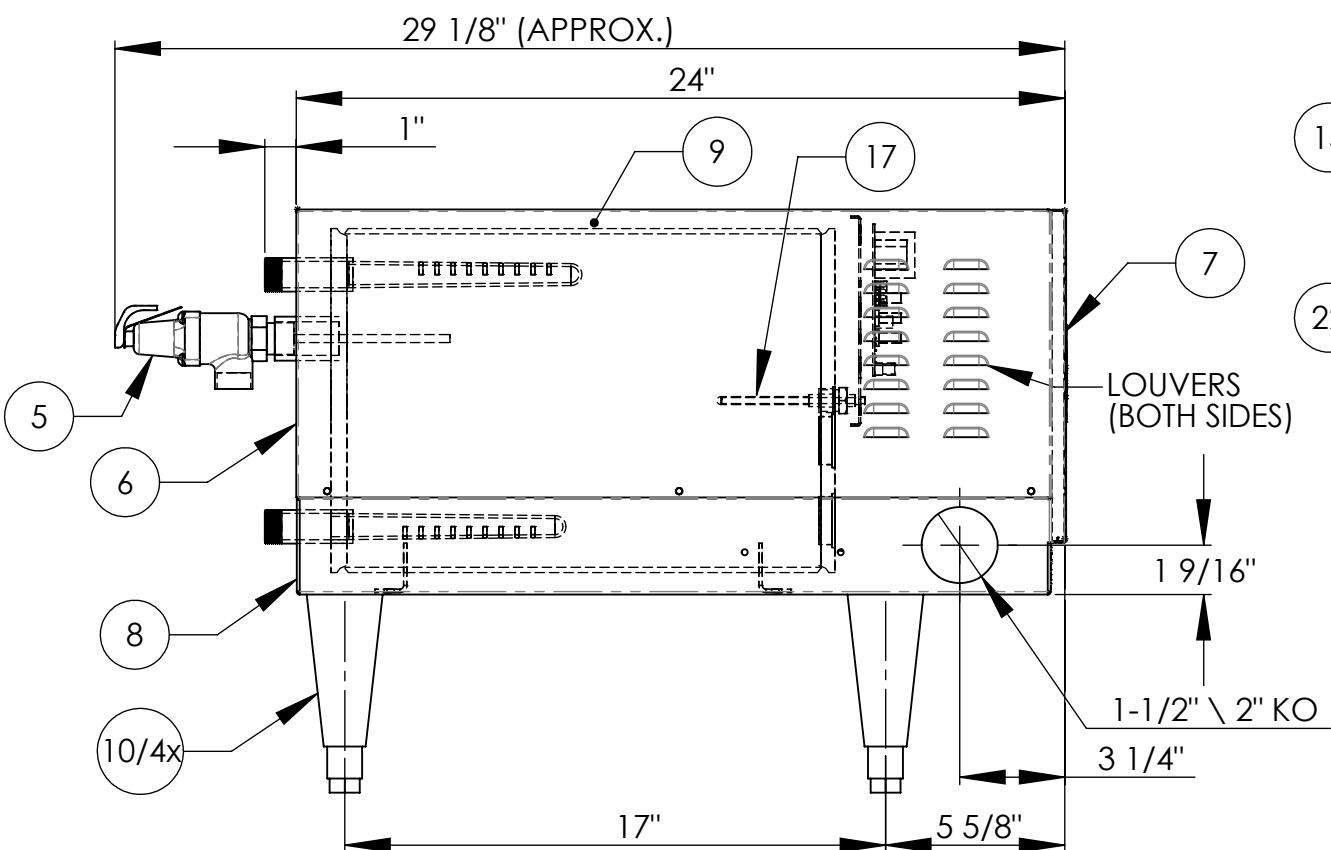
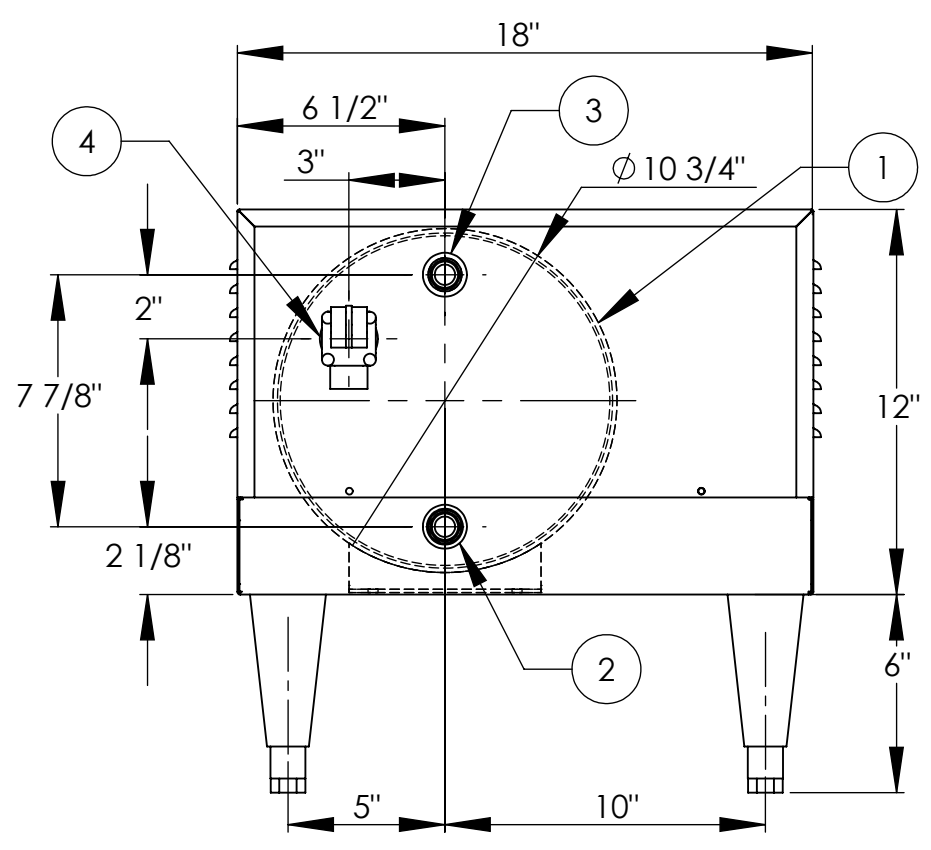

INSTALLATION REQUIREMENTS	
AMP Draw	99.9
Min. Breaker/Fuse Size	125 AMP
Cu Power Feed Wire	#1 AWG THHN
Min. Power Conduit	1 1/4"
Wiring Diagram	12 (NCB)

ELECTRICAL NOTES:
 1. POWER FEED WIRE SIZING IS BASED ON 75°C Cu THHN WIRE WITH FEEDER BRANCH PROTECTION AT 125%.
 2. REFERENCE INSTALLATION, OPERATION, AND MAINTENANCE MANUAL FOR COMPLETE INSTALLATION INSTRUCTIONS.

PROPRIETARY AND CONFIDENTIAL
 THE INFORMATION CONTAINED IN THIS DRAWING IS THE SOLE PROPERTY OF THE ELECTRIC HEATER COMPANY. ANY REPRODUCTION IN PART OR AS A WHOLE WITHOUT THE WRITTEN PERMISSION OF THE ELECTRIC HEATER COMPANY IS PROHIBITED.

DIMENSIONS ARE IN INCHES
 TOLERANCES:
 (UNLESS OTHERWISE SPECIFIED)
 FRACTIONAL ±1/16"
 ANGULAR: MACH ±1/2° BEND ±1°
 TWO PLACE DECIMAL ±0.01
 THREE PLACE DECIMAL ±0.005

Hubbell Stratford, CT 06615 (203) 378-2659
The Electric Heater Company

Customer: J MODEL BOOSTER HEATER J636R - 6 GALLON 36kW - 208V - 3Ø

SIZE	DWG. NO.	REV
C	J636R	-

SCALE: 1:6 FSCM: 19857 SHEET 1 OF 1

ATTACHMENT D
QUALIFICATIONS (Experience of Contractor on other similar work)

Business and Type of Job	Contact name	Phone/Email	Dates of Project (start – end)	Total Project Amount

PRIMARY OFFICE/BRANCH (List the address of principle office/branch and the nearest to University location that would provide the services/equipment necessary to meet the terms and conditions listed in this bid and incorporated into an awarded contract.)

Primary Office Address	Principle Contact	Phone	E-mail
Nearest Branch Address	Principle Contact	Phone	E-mail

For Use of Respondent:

Signature of Authorized Official: _____

Title: _____ Date: _____

For Use of Department of Procurement:

Approved _____ Date: _____

UNIVERSITY TERMS & CONDITIONS

The following terms and conditions apply to all Successful Respondents. By participating in this Competitive Solicitation process, Respondent agrees to be bound by the additional terms and conditions:

- 1) **Payment.** The Contractor will submit invoices for fees or other compensation for Goods/Services or expenses in detail sufficient for a proper pre-audit and post-audit.
 - a) Upon receipt, the University has five (5) business days to inspect and approve the goods or services.
 - b) The University will make payment in accordance with the University's Regulation, which states the Contractor's rights as a vendor and the University's responsibilities concerning interest penalties and time limits for payment of invoices.
 - c) If a payment is not issued within thirty (30) days of receipt of a proper invoice and receipt and inspection and approval of the goods and services, the University, upon a valid request, will pay to the Contractor, in addition to the amount of the invoice, an interest penalty at the rate established pursuant to Section 55.03(1), Florida Statutes, provided the interest penalty is in excess of one dollar (\$1.00). The interest will be calculated on the unpaid balance from the expiration of the 30-day period until such time as the payment is issued to the Contractor.
 - d) A Vendor Ombudsman, whose duties include acting as an advocate for Contractors who may be experiencing problems in obtaining timely payment from the University, may be contacted at 863-874-8448.
- 2) **Cooperation on Audits and Investigations.** The Contractor must cooperate with the University and provide specific records and/or access to the Contractor's records related to the Agreement for purposes of conducting an audit or investigation. The University will provide Contractor with reasonable notice of the need for such records or access.
- 3) **Travel Expenses.** Contractor will not charge the University for any travel expenses, meals, and lodging unless otherwise specifically provided for in the Agreement, and upon the University's prior written approval of the expenses. Under such circumstances, Contractor is authorized to incur the agreed to travel expenses which will be payable by the University, but only to the extent permitted in Section 112.061, Florida Statutes. Contractor is responsible for any expenses in excess of these prescribed amounts.
- 4) **Taxes.** The University is a tax immune sovereign and exempt from the payment of sales, use, or excise taxes. The Contractor must pay all personal property taxes on leased equipment and all taxes based upon net income.
- 5) **Relationship of the Parties.** The Contractor is an independent contractor, and neither the Contractor nor the Contractor's employees, agents, or other representatives are the University's employees or agents. The Contractor may not use the University's name, trademarks, logos, or marks without the University's prior written approval. The Contractor assumes all risk of personal injury and property damage attributable to the willful or negligent acts or omissions of itself and of its subcontractors or persons otherwise acting or engaged to act at the instance of the Contractor in furtherance of its obligations under the Agreement.
- 6) **Background Checks.** Prior to any of Contractor's (or subcontractor's) employees or agents entering the University's campus or premises to perform work pursuant to the Agreement, Contractor must have conducted, and the employee or agent must have passed, a background check. In addition, if Contractor's (or subcontractor's) employee or agent is listed on the Florida or National Sex Offenders Registry, that employee or agent may not enter the University's campus or premises in furtherance of the Agreement.
- 7) **Parking.** The Contractor must ensure that all of Contractor's and Contractor's employees', agents', and subcontractors' vehicles parked on the University premises have proper parking permits. All vehicles must be registered with and have parking permits purchased from the University's Parking and Transportation Services Department. Contractor and Contractor's employees, agents and subcontractors must observe all parking rules. The failure to purchase parking permits and otherwise comply with all the University's parking rules could result in the ticketing and/or the towing of Contractor's or Contractor's employees', agents', and subcontractors' vehicles.
- 8) **Contractor's Employment of Unauthorized Aliens.** Employment of unauthorized aliens is considered a violation of Section 274A(e) of the Immigration and Nationality Act. If the Contractor knowingly employs unauthorized aliens, the University may terminate the Agreement immediately upon notice to Contractor for Contractor's violation of this provision.
- 9) **E-Verify.** All terms defined in Section 448.095, Florida Statutes are adopted and incorporated into this provision. Pursuant to Section 448.095, Florida Statutes, Contractor certifies (Exhibit I) that it is registered with and uses the U.S. Department of Homeland Security's E-Verify system to verify the employment eligibility of all new employees hired by the Contractor during the term of the Agreement. If Contractor enters into a contract with a subcontractor to perform work or provide services pursuant to the Agreement, Contractor must also require the subcontractor to comply with the requirements of Section 448.905, Florida Statutes. The subcontractor must provide to the Contractor an affidavit stating that the subcontractor does not employ, contract with, or subcontract with or to, any unauthorized alien. Contractor must maintain a copy of such affidavit for the duration of the Agreement. The University may terminate the Agreement immediately upon notice to Contractor for Contractor's violation of this provision.
- 10) **Workers' Compensation.** Contractor must have and maintain during the life of the Agreement, Workers' Compensation Insurance for all its employees connected with the work related to the Agreement. In the event any work related to the Agreement is sublet or subcontracted, the Contractor must require the subcontractor to provide Workers' Compensation Insurance for all of the subcontractor's employees unless such employees are covered by the protection afforded by the Contractor. Such insurance must comply fully with the Florida Workers' Compensation law. In case any class of employees engaged in hazardous work under the Agreement is not protected under Workers' Compensation, the Contractor must provide, and cause each subcontractor to provide, adequate insurance for the protection of such employees.
- 11) **Equal Opportunity.** The Contractor will not discriminate against any employee or applicant for employment because of race, color, religion, sex, national origin, Veteran status, marital status, age or disability.
 - a) The Contractor will comply with the provisions of Executive Order 11246, September 24, 1965, as amended by Executive Order 11375, and the rules, regulations and relevant orders of the Secretary of Labor that are applicable to each order placed against the Contract regardless of value.

If the Contractor anticipates receiving \$10,000 in orders during the first 12 months of the Agreement, Contractor must complete the Certificate and Agreement of Non-Segregated Facilities (Exhibit II).

b) The Contractor will also comply with the Americans with Disabilities Act (ADA) of 1990, as revised.

c) If the Contractor anticipates receiving \$50,000 in orders during the first 12 months of the Agreement, and employs more than 50 people, the Contractor will complete and file prior to March 1 of each year a standard form 100 (EEO-1) and will maintain a written program for affirmative action compliance that is available for review upon the University's request.

12) Subcontractors. The Contractor is fully responsible for all work performed under the Agreement. The Contractor may, with the prior written consent of the University, enter into written subcontract(s) for performance of certain of its functions under the Agreement. The Contractor's subcontracts must not be implemented or effective until and unless approved in writing by the University. Contractor will fully notify any subcontractors of Contractor's responsibilities pursuant to the Agreement by providing language in the Contractor's subcontracts with subcontractors for work related to the Agreement. Contractor is solely responsible for all payments to its subcontractors. Contractor will require its subcontractors to provide proof of the required insurance coverage as well as proof of appropriate licenses before allowing the subcontractor to perform work related to the Agreement.

13) Small Business Minority Enterprise (SBME) Reporting. In each invoice submitted to the University, the Contractor will report the following information for each SBME used in the performance of the Agreement: the Name, Address, Type of Certification and Dollar Amount paid for work related to the Agreement.

14) Covenant Against Commissions or Brokerage and Contingent Fees. Contractor warrants that the Contractor has not paid or agreed to pay any person, company, corporation, individual, or firm, other than a bona fide employee working solely for the Contractor, any fee, commission, percentage, gift, or other consideration contingent upon or resulting from the award or making of the Agreement. In the event of Contractor's breach or violation of this warranty, the University has the right to terminate the Agreement, without liability, and to deduct from any amounts otherwise payable to Contractor under the Agreement the full amount of such fee, commission, percentage, gift, or other consideration, and to pursue any other remedy available to the University under the Agreement, at law or in equity.

15) Insurance. Contractor will maintain, at its own expense, amounts of insurance as required in the Solicitation. If no insurance is mandated in the Solicitation, Contractor must at a minimum maintain insurance that covers the Contractor's exposure in performing the Agreement. The University is self-insured and is not required to obtain additional insurance for purposes of the Agreement.

16) Licensing Requirements. To the extent applicable, Contractor must have and maintain all appropriate licenses necessary to provide the Goods/Services related to the Agreement. Contractor must provide proof of such licenses to the University upon request.

17) Work for Hire. Any work specifically created for the University under the Agreement is considered a "work for hire." All designs, prints, paintings, artwork, sketches, etchings, drawings, writings, photographs, or any other work or material or property produced, developed or fabricated and any other property created hereunder, including all material incorporated therein and all preliminary or other copies thereof, (the "Materials") are and remain the property of the University, and, unless otherwise specifically set forth herein, are considered specially ordered for the University as a "work made for hire," or, if for any reason held not to be a "work for hire," the Contractor (or subcontractor or agent) who created, produced, developed or fabricated the Materials hereunder assigns all of his/her/its right, title and interest in the Materials to the University.

a) The University owns all right, title and interest in the Materials. Contractor agrees upon request to take the necessary actions (and if necessary, ensure the Contractor's subcontractor or agent takes the necessary actions) to perfect the transfer of such title to the University.

b) The Materials must be to the University's satisfaction and are subject to the University's approval. Contractor bears all risk of loss or damage to the Materials until the University has accepted delivery of the Materials.

c) The University is entitled to return, at Contractor's expense, any Materials which the University deems to be unsatisfactory.

d) On or before completion of the Contractor's services hereunder, the Contractor must furnish the University with valid and adequate releases necessary for the unrestricted use of the Materials for advertising or trade purposes, including model and property releases relating to the Materials and releases from any persons whose names, voices or likenesses are incorporated or used in the Materials.

e) The Contractor warrants that the Materials may be used or reproduced for advertising or trade purposes or any commercial purposes without violating any laws or the rights of any third parties and that no third party will have any rights in, to, or arising out of, or in connection with the Materials, including without limitation any claims for fees, royalties, or other payments.

18) Trademark or Copyright Infringement. The Contractor will, at its expense, defend any suit brought against the University and will indemnify the University against an award of damages and costs made against the University by settlement or final judgment of a court that is based on a claim that the use of the Contractor's product infringes a trademark or copyright of a third party; provided that the University notifies the Contractor in writing of the suit or any claim of infringement within thirty (30) days after receiving notice thereof, and further provided that the Contractor is permitted to control the defense in any litigation or settlement of the suit. The University will provide reasonable cooperation in the defense of the suit at the Contractor's expense. Such defense and indemnity survives termination or expiration of the Agreement.

19) Confidentiality of Information.

a) The Contractor acknowledges and agrees that the following items are and remain confidential, proprietary, and the sole property of the University:

- i) all documents, studies, materials and information furnished to the Contractor by the University or the University's affiliates in connection with the Agreement, and
- ii) all reports, studies, plans, deliverables, strategies, materials and other documents and information developed or prepared for the University in connection with the Agreement or which reflect any of the documents, studies, materials or information furnished to the Contractor by the University (the materials described in this provision are collectively referred to as the "Information").

b) The Contractor agrees that it will not use the Information, nor share the Information with its employees, except as necessary to the Contractor's performance under the Agreement, and the Contractor will at all times comply with all state and federal laws governing the use and/or safe-keeping

of confidential and/or personally identifiable information. The Contractor must not disclose Information to third parties unless it obtains the University's written consent to such disclosure.

c) In the event the Contractor is required by subpoena or other judicial or administrative process or by law to disclose such records, the Contractor will:

- i) provide the University with prompt notice thereof;
 - ii) consult with the University on the advisability of taking steps to resist or narrow such disclosure;
 - iii) furnish only that portion of the information that is responsive to the request;
 - iv) comply with the requirements of all state and federal privacy laws applicable to the Information, which may include but is not limited to, Florida Public Records laws, FERPA, the Gramm-Leach Bliley Act, the Federal Trade Commission's Red Flags Rule (which implements Section 114 of the Fair and Accurate Credit Transactions Act of 2003); and
 - v) reasonably cooperate with the University in any attempt that the University may make to obtain an order or other reliable assurance that confidential treatment will be accorded the records.
- d) Upon termination of the Agreement or upon request by the University, the Contractor will promptly return the Information to the University. Notwithstanding the foregoing, if the University will share or provide access to protected health information or "PHI" with the Contractor for the Contractor to perform the Agreement, the University and the Contractor will enter into a separate business associate agreement which will govern the confidentiality and non-use obligations of the Agreement regarding the PHI (in lieu of this provision). This provision survives the termination or expiration of the Agreement.

20) Compliance with Public Records Law. The University is subject to applicable public records laws as provided by provisions of Florida Statutes Chapter 119, and the University will respond to such public records request without any duty to give the Contractor prior notice. The University may unilaterally terminate the Agreement for Contractor's refusal to allow public access to all public records that were made or received in conjunction with the Agreement. This provision survives termination or expiration of the Agreement.

IF THE CONTRACTOR HAS QUESTIONS REGARDING THE APPLICATION OF CHAPTER 119, FLORIDA STATUTES, TO THE CONTRACTOR'S DUTY TO PROVIDE PUBLIC RECORDS RELATING TO THE AGREEMENT, CONTACT THE CUSTODIAN OF PUBLIC RECORDS AT: (863) 874-8412, ogc@floridapoly.edu, Florida Polytechnic University, Attention: General Counsel, 4700 Research Way, Lakeland, FL 33805.

a) To the extent that Contractor meets the definition of "contractor" under Section 119.0701, Florida Statutes, in addition to other requirements provided by law, Contractor must comply with public records laws, including the following provisions of Section 119.0701, requiring Contractor to:

- i) Keep and maintain public records required by the University to provide the Goods/Service.
 - ii) Upon request from the University, provide the University with a copy of the requested records or allow the records to be inspected or copied within a reasonable time at a cost that does not exceed the cost provided in Chapter 119 or as otherwise provided by law.
 - iii) Ensure that public records that are exempt or confidential and exempt from public records disclosure requirements are not disclosed except as authorized by law for the duration of the Agreement term and following completion of the Agreement if the Contractor does not transfer the records to the University.
 - iv) Upon completion of the Agreement contract, transfer, at no cost, to the University all public records in possession of the Contractor or keep and maintain public records required by the public agency to perform the service. If the Contractor transfers all public records to the public agency upon completion of the Agreement, the Contractor shall destroy any duplicate public records that are exempt or confidential and exempt from public records disclosure requirements. If the Contractor keeps and maintains public records upon completion of the Agreement, the Contractor shall meet all applicable requirements for retaining public records. All records stored electronically must be provided to the University, upon request from the University's custodian of public records, in a format that is compatible with the information technology systems of the University.
- b) The University may inspect the:
- i) Financial records, papers, and documents of the Contractor that are directly related to the performance of the Agreement or the expenditure of state funds.
 - ii) The Contractor's programmatic records, papers, and documents which the University determines are necessary to monitor the performance of the Agreement or to ensure that the terms of the Agreement are being met.
 - iii) The Contractor must provide such records, papers, and documents requested by the University within 10 business days after the request is made.
 - iv) The right of access in this provision is not limited to the required retention period but lasts as long as the records are retained.
- c) The terms of this section 23 Compliance with Public Record Laws are material terms of the Agreement, and failure to comply may result in termination of the Agreement and/or civil penalties.

21) Termination.

- a) Termination for Cause. Either party may terminate the Agreement for cause by giving the other party thirty (30) calendar-days written notice and an opportunity to cure by setting forth with specificity the basis for the termination of the Agreement for cause. For purposes of the Agreement, "cause" means the failure by either party to: (i) provide the Goods/Services within the time specified in the Agreement; or (ii) adhere to any terms of the Agreement.
- b) Termination for Convenience. The Agreement may be terminated by the University for convenience by providing written notice to Contractor of such intent to terminate at least 10 days prior to the effective date of such termination.
- c) If the Agreement is terminated, the University is liable only for payment of Goods/Services received or rendered and accepted by the University prior to the date of termination.

22) Convicted Vendor List. The Contractor represents and warrants that it is not on the Convicted Vendor List (see Fla. Stat. § 287.133(2)(a)).

23) Annual Appropriations. The State of Florida and the University's performance and obligation to pay under the Agreement are subject to and contingent upon sufficient appropriations by the Florida Legislature and other entities' allowance of the University to use such funds. In the event the

entities controlling such funding fail to appropriate funds or to allow the University to use such funds, and the University has determined, in the University's sole discretion, that there are insufficient funds available to cover the University's obligation under the Agreement, the University may terminate the Agreement without damage, penalty, cost or further obligation. The University will give notice to the Contractor of the non-availability of funds when the University has knowledge thereof. Upon receipt of such notice by the Contractor, the Contractor is entitled to payment only for those Goods/Services performed and accepted by the University prior to the date such notice is received.

24) Waiver of Rights and Breaches. No right conferred on the University by the Agreement is deemed waived and no breach of the Agreement excused unless such waiver of right or excuse of breach is in writing and signed by the University. The University's waiver of a right or excuse of breach does not constitute a waiver or excuse of any other right or breach.

25) Federal, State, Local Laws, and Regulations. The Contractor and any subcontractors must comply with all applicable laws, ordinances, and regulations.

26) Force Majeure. In the event compliance with any obligation under the Agreement is impractical or impossible due to any Event of Force Majeure, then the time for performance of such obligation will be extended for a period equivalent to the duration of the Event of Force Majeure. The provisions of this section do not excuse either party's inability to perform its obligations hereunder because of inadequate finances. "Event of Force Majeure" means any strike, lockout, labor dispute, embargo, flood, earthquake, storm, dust storm, lightning, fire, epidemic, act of God, war, national emergency, civil disturbance or disobedience, riot, sabotage, terrorism, restraint by governmental order or any other occurrence beyond the reasonable control of the party in question.

27) Lobbying. Contractor is prohibited from using funds provided under the Agreement for the purpose of lobbying the Legislature or any official, officer, commission, board, authority, council, committee, or department of the executive branch or the judicial branch of state government.

28) Assignment/Modification of Agreement. The Agreement may not be assigned or modified by either party except as agreed to in writing and signed by both parties. The Agreement is binding upon the parties' successors and assigns.

29) Indemnification. The Contractor is responsible for its performance under the Agreement. The Contractor will indemnify and hold harmless, assume liability for and defend, the State of Florida, the Florida Board of Governors, the University and their officers, employees, and agents, from and against any and all actions, claims, liabilities, assertions of liability, losses, costs and expenses, which may arise in any manner or are alleged to have arisen, from the acts, omissions or wrongful conduct of Contractor or Contractor's officers, employees, agents, guests, patrons, licensees, invitees or subcontractors in connection with or related to their operations, activities, and/or occupancy or use of the University premises in performance of the Agreement. This provision survives termination or expiration of the Agreement. The Contractor's obligations under this provision do not extend to any liability caused by the sole negligence of the University or its officers, agents, or employees.

30) Sovereign Immunity. Nothing in the Agreement is to be construed as an indemnification of the Contractor by the University or as a waiver of sovereign immunity beyond that provided in Section 768.28, Florida Statutes.

31) Governing Law; Venue. The Agreement is governed by the laws of the State of Florida and will be construed, performed, and enforced in all respects in accordance with the laws and rules of the State of Florida. Any disputes related to the Agreement will be governed by Florida law, and the Agreement is deemed to have been executed and entered into in the State of Florida. Exclusive venue of any actions arising out of the Agreement will be in the courts in Polk County, Florida.

32) Use of Agreement by Other Governmental Agencies. At the option of the Contractor, the use of the Agreement may be extended to other governmental entities, including the State of Florida, its agencies, political subdivisions, counties, and cities, and any university in the State University System of Florida. Each such entity using the Agreement does so independently of the University and is solely responsible for its duties under its own agreement.

33) F.O.B. for Deliveries. For shipping and delivery of goods, shipping charges are included in the price of the goods and the shipped goods become the legal property and responsibility of the University only after the goods have been delivered and the University has inspected and accepted the goods; Contractor is responsible for the goods until such time.